



NEW HOLLAND BOOMER™ EASYDRIVE™

BOOMER 45D EASYDRIVE™ | BOOMER 54D EASYDRIVE™



**MACHINE
OF THE YEAR 2015**

GREATER POWER, DELUXE COMFORT AND EASE

New Holland has now responded to customer feedback, increased power, convenience and comfort are part of the design of the deluxe Boomer™ 45D EasyDrive™ and Boomer™ 54D EasyDrive™ tractor range. Both models are offered with the unique EasyDrive™ CVT Transmission which takes operating efficiency to a whole new level. Deluxe operator features are included as standard comprising of class leading operator space, tilting/telescoping steering wheel, premium seat with swivel and air conditioning.



CLEAN-RUNNING TIER 4B ENGINE

The new Boomer 54D model is powered by a new three-cylinder engine that features a common-rail, direct-fuel-injection system for maximum fuel efficiency, and boasts 3hp more than its predecessor 3050 model. The engine also meets tough Tier 4B emissions standards, so they reduce greenhouse gas and hydrocarbon pollution for better stewardship of the land.

MORE TORQUE FOR INCREASED PERFORMANCE

The 45-horsepower engine in the Boomer 45D produces 140Nm of torque, while the 54-horsepower Boomer 54D engine features 180Nm of torque, for smooth performance in extreme conditions. Thanks to torque efficiency, you can also operate at lower engine speeds for better fuel economy.

FILL UP LESS OFTEN

You can operate for longer periods in between fill-ups thanks to one of the industry's largest-capacity fuel tanks. The 54 liter tank is located at the rear of the tractor, and also has a wide fill neck for easy refueling.



EASYDRIVE™: THE NAME SAYS IT ALL

The EasyDrive™ continuously variable transmission (CVT) is designed to provide smooth, seamless speed changes through varying conditions. EasyDrive™ controls are unique, featuring a single pedal to control both travel speed and engine speed. Just press the single pedal and go - the transmission automatically adjusts to deliver the desired speed and match load conditions. Change directions using a convenient shuttle like those found on larger tractors. The lever is mounted on the left side under the steering wheel for easy operation.

ADDITIONAL EASYDRIVE™ ADVANTAGES

The EasyDrive™ CVT gets the job done efficiently, so whatever you're doing feels less like work and more like fun. This innovative transmission offers an automotive-style cruise control, allowing you to hold, fine-tune, or resume working speeds. A response setting allows operators to adjust the acceleration and deceleration characteristics of the tractor to suit their driving style or application. In slippery conditions, just engage four-wheel drive electronically with the flick of a switch. With a speed range up to 18.6mph, you are sure to get all your jobs done fast.



• Basic Control Panel



Sustainable Efficient Technology

ADVANCED AFTERTREATMENT

The New Holland emissions treatment system on the 54D model uses a combination of internal Exhaust Gas Recirculation (EGR) to control Nitrogen Oxides (NOx) and a Particulate Matter (PM) catalyst. The PM Catalyst system has two unique sections - a Diesel Oxidation Catalyst (DOC) that turns Nitrous Oxide (NO) into Nitrogen Dioxide (NO₂) and a soot collection and combustion chamber that captures the remaining soot. Unlike other tractors that require extra fluids, operator input or that require you to stop operations, the New Holland system is completely automatic and requires zero maintenance.

YOU'VE BEEN UPGRADED TO THE SUITE

For the most comfortable environment available in a compact tractor, look no further than to the SuperSuite cab, available on the Boomer™ 45D and Boomer 54D. Air conditioning and full heating allow the operator to enjoy all day comfort, protected from weather, insects, dust, and noise. For easy storage and access to low buildings, the low cab height of 2.35m offers added versatility.



SPACIOUSNESS COMES STANDARD

Step inside the SuperSuite cab, you'll find the legroom, hip room, and headroom to be more than generous. In fact, the SuperSuite cab is the largest in its class, with 1.7m³ of interior space surrounding you. Two large doors with grab rails open on gas struts to wide entry thresholds for easy entry and exit on either side. To maximize your comfort and visibility, the new premium seat glides on an inclined track to place you at the right spot. It also features over 7.5cm of vertical suspension and swivels 20 degrees to the right, making it easy to view your work or the implement behind you.

VISIBILITY COMES FIRST

You will instantly see the difference 4.4 square metres of glass makes. It adds up to 360° visibility that cannot be matched in any other compact tractor cab. The sloped bonnet gives you excellent forward visibility from the tractor seat. That's because the exhaust is under the bonnet and not in your line of sight like competitive tractors.

HIGH-VISIBILITY ROOF PANEL

A standard high-visibility roof panel allows you to see the loader through its full range of operation for safe, efficient and fatigue-free operation.



HYDRAULIC POWER AND FLEXIBILITY

The rear linkage of Boomer EasyDrive™ tractors will lift up to 1600kg. The powerful hydraulic pump delivers a generous 37.9 litres per minute, with a separate 20.5 litres per minute pump for the power steering. Two rear remotes are standard with a third available. Mid-mount valves can be specified.

Minimum turning radius

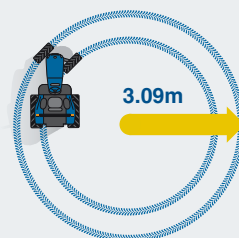

Maximum lift capacity

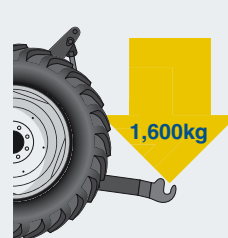

Maximum hydraulic flow

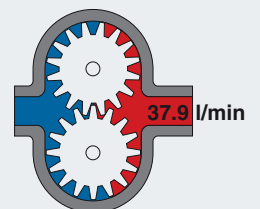

LEWIS 30 SERIES. COMPACT LOADERS FOR COMPACT TRACTORS.

Designed specifically to fit the New Holland compact tractors from 27-54hp(CV), the LEWIS 30 SERIES are tailor made for your tractor. A quick hitch design makes fitting and removal of the loader as easy as possible, and a 'quick-attach' headstock is standard for our comprehensive range of attachments. Our low maintenance loaders feature greaseless bushings, tough powder coat finish and the hydraulic hoses are run inside the arms to prevent damage in use.



QUICK RELEASE FRAME

The 'quick-attach' headstock is standard to the whole LEWIS 30 SERIES and enables the operator to quickly and easily change between our comprehensive range of attachments without the use of tools.

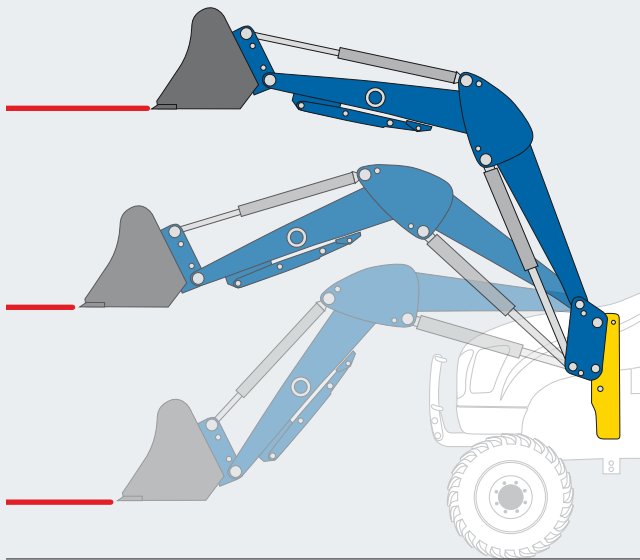

MECHANICAL SELF-LEVELLING

If you need to maintain a fixed position to speed up the loading process, then mechanical self-levelling is for you. It is ideal for operations which extensively stack pallets.

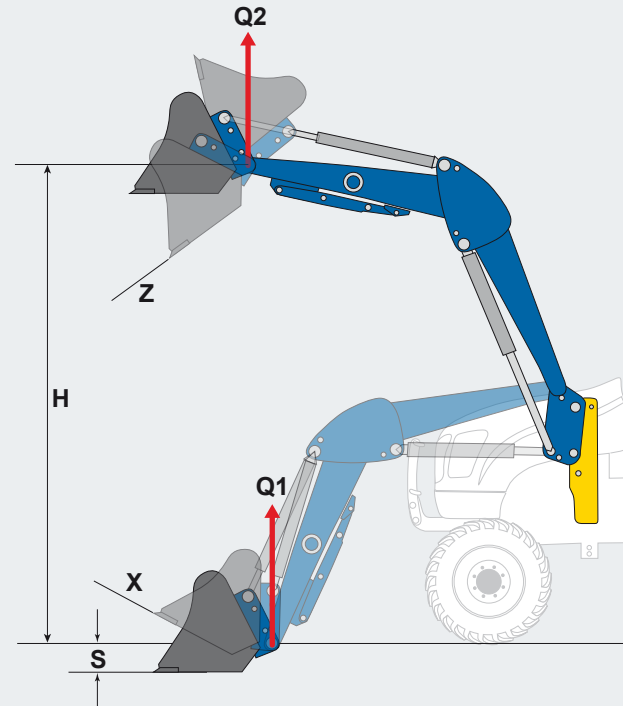

MODEL

LEWIS 3530

Self Levelling System	NSL	MSL
Q1 Max. lift capacity at lower arm pivot point (kg)		900
Q2 Max. lift capacity at upper arm pivot point (kg)		600
Weight without tool and attached parts (kg)	220	220
H Max. lift height at pivot (mm)		2460
S Dig depth (mm)		215
X Tilt angle (°)		37
Z Dump angle loader up (°)		37
Min. tractor power [kW/hp(CV)]		29/40
Max. tractor power [kW/hp(CV)]		40/55
3rd Service		○
Lewis quick-release frame		●
New Holland Blue colour		●

NSL = Non Self Levelling MSL = Mechanical Self Levelling

● Standard ○ Optional

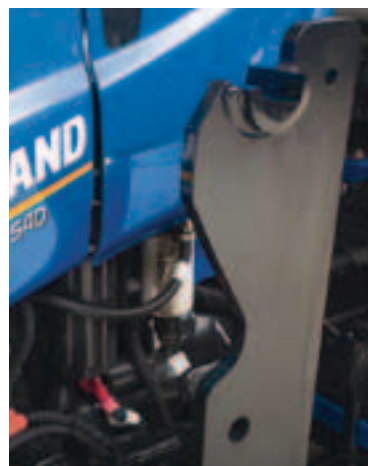

SIMPLE ATTACHMENT

A simple, easy to use system ensures that the loader is securely attached yet easy to remove when not required. The colour coded hydraulic lines are instantly attached and the loader arms and brackets are easy to align for hassle free attachment. The improved location of the Boomer™ EasyDrive™ mid-mount valves makes connecting the loader hydraulics a breeze.



ERGONOMIC MECHANICAL JOYSTICK

You can choose just where you want to position the easy to use mechanical joystick.

SPECIFICATIONS

MODELS

BOOMER™ 45D EASYDRIVE™

BOOMER™ 54D EASYDRIVE™

Engine*		
No. of cylinders / Aspiration / Valves / Emission level	4 / NA / 2 / Tier 3-Stage 3A	3 / T / 2 / Tier 4B-Stage 4
Capacity (cm³)	2200	2200
Rated Power - ISO TR14396 - ECE R120 @ rated speed [kW/hp(CV)]	33.5/46 @ 2600rpm	39.5/54 @ 2600rpm
Max. Torque ISO TR14396 (Nm)	140 @ 1800rpm	180 @ 1800rpm
Fuel tank capacity (L)	54	54
Transmission		
Constantly Variable Transmission	EasyDrive™ CVT Transmission	
Number of ranges	Infinitely variable	Infinitely variable
Minimum speed / Maximum speed (kph)	0 / 30	0 / 30
Front axles		
4WD front axle	●	●
Steering angle (°)	54	54
Hydraulics		
Main pump flow / Pump pressure (Lpm / Bar)	37.9 / 172	37.9 / 172
Steering pump flow (Lpm)	20.5	20.5
Remote valves Std. / Max. no. rear valves (No.)	2 / 3	2 / 3
Linkage		
Max. lift capacity at ball ends (kg)	1600	1600
PTO		
Rear PTO (rpm)	540	540
Rear PTO engines speed (rpm)	2405	2600
Operator environment		
SuperSuite Cab with integral high visibility panel and air conditioning	●	●
Basic control panel	●	●
Tyres		
Turf front / rear	27 x 10.5-15 / 44 x 18-20	
Agricultural front / rear	8 x 16 / 14.9 x 24	
Industrial front / rear	10.0 x 16.5 / 17.5 x 24	
Golf front / rear	27 x 12LL-15 / 22.5LL x 16.1	
Dimensions		
Optimum turn radius (mm)	3099	3099
Wheelbase (mm)	1867	1867
Overall length (mm)	3099	3099
Minimum overall width ag tyres (mm)	1687	1687
Height to top of cab (on turf tyres) (mm)	2230	2230
Height at centre rear axle to top of cab (mm)	1726	1726
Ground clearance min. (mm)	318	318
Track setting front / rear (mm)	1204 / 1309 or 1712	1204 / 1309 or 1712
Weight with cab (kg)	1673	1700

● Standard * Developed by FPT Industrial for Boomer 54D EasyDrive™

All dimensions use agricultural tyres

AT YOUR OWN DEALER



NEW HOLLAND TOP SERVICE
00800 64 111 111

The call is free from a land line. Check in advance with your Mobile Operator if you will be charged. Alternatively call 01 2421881.



www.newholland.com/uk - www.newholland.com/ie

New Holland with



The data indicated in this folder are approximate. The models described here can be subjected to modifications without any notice by the manufacturer. The drawings and photos may refer to equipment that is either optional or intended for other countries. Please apply to our Sales Network for any further information. Published by New Holland Brand Communications. Bts Adv. - Printed in Italy - 06/15 - TP01 - (Turin) - 150011/INB