

McCormel **55**SERIES



POWER ARM
55 SERIES

- PA5155 - 5.1m (16' 9") reach
- PA5455 - 5.4m (17' 9") reach
- PA5555-60 - 5.5m (18' 1") reach
- PA5755-60 - 5.7m (18' 9") reach

55 SERIES

Advanced Controls	PA5155	PA5455	PA5555-60	PA5755-60
Cable Control	<input type="checkbox"/>	<input type="checkbox"/>	<input type="checkbox"/>	<input type="checkbox"/>
Motion Mini	—	—	—	—
Motion	<input type="checkbox"/>	<input type="checkbox"/>	<input type="checkbox"/>	<input type="checkbox"/>
Evolution	<input type="checkbox"/>	<input type="checkbox"/>	<input type="checkbox"/>	<input type="checkbox"/>
Revolution Including Easy Drive System (EDS)	—	—	—	—
Two-way Rotor Engagement - Cable Control (CRC)	<input type="checkbox"/>	<input type="checkbox"/>	<input type="checkbox"/>	<input type="checkbox"/>
Two-way Rotor Engagement - Electric Control (ERC)*	<input type="checkbox"/>	<input type="checkbox"/>	<input type="checkbox"/>	<input type="checkbox"/>
Mounting				
Front 3-Point Mounting Including Stabiliser	—	—	—	—
Front DIN Plate Mounting	—	—	—	—
Rear 3-Point Mounting Including Stabiliser	■	■	■	■
Rear 3-Point to 4-Point Hitch Stabiliser Kit	<input type="checkbox"/>	<input type="checkbox"/>	<input type="checkbox"/>	<input type="checkbox"/>
Rear 3-Point to 5-Point Axle Mounting Kit**	—	—	—	—
Rear 5-Point Rigid Frame, Axle Mounting Kit**	—	—	—	—
Armsets				
Straight Armset	<input type="checkbox"/>	■	■	■
Midcut Armset	—	—	—	—
Telescopic Armset	—	—	—	—
Variable Forward Reach Armset (VFR)	<input type="checkbox"/>	—	—	—
Telescopic-Variable Forward Reach Armset (T-VFR)	—	—	—	—
Parallel Arm Geometry	■	■	■	■
Hydraulics				
Horsepower	55hp	55hp	60hp	60hp
System Type	Gear	Gear	Gear	Gear
Pump Type	Cast	Cast	Cast	Cast
Total Flow Rate l/min	122.0	122.0	122.0	122.0
Arm Circuit Flow Rate l/min	19.0	19.0	19.0	19.0
Attachment Circuit Flow Rate l/min	103.0	103.0	103.0	103.0
Oil Tank Capacity	180ltrs	180ltrs	180ltrs	180ltrs
Oil Cooler	<input type="checkbox"/>	<input type="checkbox"/>	■	■
Totally Independent Hydraulic System	■	■	■	■
Hydraulic Upgrades				
Angle Float Kit	<input type="checkbox"/>	<input type="checkbox"/>	<input type="checkbox"/>	<input type="checkbox"/>
Lift Float Kit	<input type="checkbox"/>	<input type="checkbox"/>	<input type="checkbox"/>	<input type="checkbox"/>
Advanced Float Kit (only on EVOLUTION controls)	—	—	—	—
EDS (only on REVOLUTION controls)	—	—	—	—
PowerBoost (75 l/min Arm Circuit Flow Rate)	—	—	—	—
Additional Hydraulic Services	<input type="checkbox"/>	<input type="checkbox"/>	<input type="checkbox"/>	<input type="checkbox"/>
Safety Equipment				
External Debris Blower	<input type="checkbox"/>	<input type="checkbox"/>	<input type="checkbox"/>	<input type="checkbox"/>
Integrated Debris Blower	—	—	—	—
Road Lighting Kit	<input type="checkbox"/>	<input type="checkbox"/>	■	■
Warning Arrow Kit	<input type="checkbox"/>	<input type="checkbox"/>	<input type="checkbox"/>	<input type="checkbox"/>
Window Guards	■	■	■	■
Cab Protection Kit	—	—	—	—
Safety Breakaway	■	■	■	■
Power Slew	■	■	■	■
Cushioned Top Link	—	—	—	—
Tractor Requirements				
Minimum Tractor Weight	3,000kg	3,500kg	3,500kg	3,500kg
Minimum Tractor Horsepower	70hp	70hp	70hp	70hp
Specification				
Machine Weight #	881kg	895kg	905kg	915kg
Left and Right-Hand Build Options	<input type="checkbox"/>	<input type="checkbox"/>	<input type="checkbox"/>	<input type="checkbox"/>

* Including SoftStart ** Excluding axle brackets & latches # Depending on specification, excluding attachment & oil

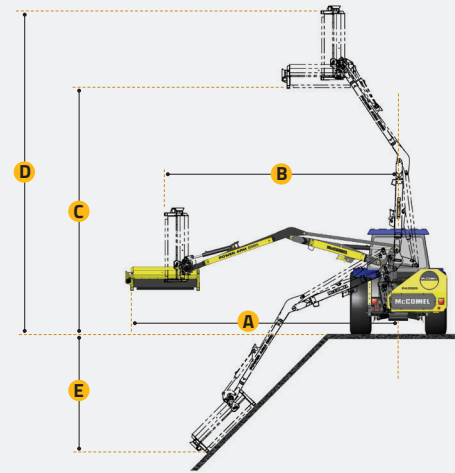

REACH DIMENSIONS

	PA5155	PA5455	PA5555-60	PA5755-60
A	5.1m / 16' 9"	5.4m / 17' 9"	5.5m / 18' 0"	5.7m / 18' 9"
B	4.5m / 14' 9"	4.8m / 15' 9"	4.9m / 16' 0"	5.1m / 16' 9"
C	4.5m / 14' 9"	4.7m / 15' 6"	4.8m / 15' 9"	5.0m / 16' 5"
D	5.9m / 19' 6"	6.2m / 20' 4"	6.3m / 20' 8"	6.5m / 21' 4"
E	2.1m / 6' 11"	2.3m / 7' 7"	2.4m / 7' 10"	2.5m / 8' 3"

POWER ARM FLAILHEADS

	PA5155	PA5455	PA5555-60	PA5755-60
1.00m Supercut Flailhead - DD	—	—	—	—
1.20m Supercut Flailhead - DD	—	—	—	—
1.20m Multicut Flailhead - DD	<input type="checkbox"/>	<input type="checkbox"/>	<input type="checkbox"/>	<input type="checkbox"/>
1.20m Multicut Flailhead - BD	<input type="checkbox"/>	<input type="checkbox"/>	<input type="checkbox"/>	<input type="checkbox"/>
1.20m Tuffcut Flailhead - DD	—	—	—	—
1.20m Twincut Flailhead - DD	—	—	—	—
1.20m Omega Flailhead - DD	<input type="checkbox"/>	<input type="checkbox"/>	<input type="checkbox"/>	<input type="checkbox"/>
1.20m Omega Flailhead - BD	<input type="checkbox"/>	<input type="checkbox"/>	<input type="checkbox"/>	<input type="checkbox"/>
1.50m Multicut Flailhead - DD	<input type="checkbox"/>	<input type="checkbox"/>	<input type="checkbox"/>	<input type="checkbox"/>
1.50m Multicut Flailhead - BD	<input type="checkbox"/>	<input type="checkbox"/>	<input type="checkbox"/>	<input type="checkbox"/>
1.50m Twincut Flailhead - DD	—	—	—	—
1.50m Omega Flailhead - DD	<input type="checkbox"/>	<input type="checkbox"/>	<input type="checkbox"/>	<input type="checkbox"/>
1.50m Omega Flailhead - BD	<input type="checkbox"/>	<input type="checkbox"/>	<input type="checkbox"/>	<input type="checkbox"/>
1.60m Multicut Flailhead - DD	—	—	—	—
1.60m Multicut Flailhead - BD	—	—	—	—
1.60m Tuffcut Flailhead - DD	—	—	—	—
1.60m Omega Flailhead - DD	—	—	—	—
1.60m Omega Flailhead - BD	—	—	—	—
2.00m Multicut Flailhead - DD	—	—	—	—
2.00m Multicut Flailhead - BD	—	—	—	—
Flailhead				
Flailhead Skid Kit	<input type="checkbox"/>	<input type="checkbox"/>	<input type="checkbox"/>	<input type="checkbox"/>
Cushioned Grass Mowing Roller	—	—	—	—
Hydraulic Roller	<input type="checkbox"/>	<input type="checkbox"/>	<input type="checkbox"/>	<input type="checkbox"/>
Hydraulic Front Hood	—	—	—	—

■ Standard Equipment □ Optional Equipment — Not available



Designed for farmers, contractors and local government green maintenance teams, 55-series machines are robust and reliable with cast-iron pumps and gearboxes and high-capacity oil filters as standard.

Available with hy-reach and parallel arm geometry, hydraulic safety breakaway, Power Slew, and a wide range of attachments, the 55-series offers enhancements that are the envy of other mainstream mid-range Power Arms.

- 4 Reach options from 5.1m to 5.7m
- 3 Advanced control options
- 2 Mounting options
- 2 Armset option
- 2 Floatation options
- 21 Attachment options

