



POWER ARM

35 SERIES

PA4635-30 - 4.8m (15' 9") reach

PA5035-30 - 5.1m (16' 9") reach

35 SERIES

Advanced Controls	PA4635-30	PA5035-30
Cable Control	<input type="checkbox"/>	<input type="checkbox"/>
Motion Mini	<input type="checkbox"/>	<input type="checkbox"/>
Motion	—	—
Evolution	—	—
Revolution Including Easy Drive System (EDS)	—	—
One-way Rotor Engagement - Electric Control (ERC)	<input type="checkbox"/>	<input type="checkbox"/>
Two-way Rotor Engagement - Cable Control (CRC)	<input type="checkbox"/>	<input type="checkbox"/>
Two-way Rotor Engagement - Electric Control (ERC)	<input type="checkbox"/>	<input type="checkbox"/>
Mounting		
Front 3-Point Mounting Including Stabiliser	—	—
Front DIN Plate Mounting	—	—
Rear 3-Point Mounting Including Stabiliser	■	■
Rear 3-Point to 4-Point Hitch Stabiliser Kit	—	—
Rear 3-Point to 5-Point Axle Mounting Kit**	—	—
Rear 5-Point Rigid Frame, Axle Mounting Kit**	—	—
Armsets		
Straight Armset	■	■
Midcut Armset	—	—
Telescopic Armset	—	—
Variable Forward Reach Armset (VFR)	—	—
Telescopic-Variable Forward Reach Armset (T-VFR)	—	—
Parallel Arm Geometry	—	—
Hydraulics		
Horsepower	30hp	30hp
System Type	Gear	Gear
Pump Type	Aluminium	Aluminium
Total Flow Rate l/min	81.0	81.0
Arm Circuit Flow Rate l/min	12.8	12.8
Attachment Circuit Flow Rate l/min	68.2	68.2
Oil Tank Capacity	140ltrs	140ltrs
Oil Cooler	<input type="checkbox"/>	<input type="checkbox"/>
Totally Independent Hydraulic System	■	■
Hydraulic Upgrades		
Angle Float Kit	■	■
Lift Float Kit	■	■
Advanced Float Kit (only on EVOLUTION controls)	—	—
EDS (only on REVOLUTION controls)	—	—
PowerBoost (75 l/min Arm Circuit Flow Rate)	—	—
Additional Hydraulic Services	—	—
Safety Equipment		
External Debris Blower	<input type="checkbox"/>	<input type="checkbox"/>
Integrated Debris Blower	—	—
Road Lighting Kit	<input type="checkbox"/>	<input type="checkbox"/>
Warning Arrow Kit	<input type="checkbox"/>	<input type="checkbox"/>
Window Guards	■	■
Cab Protection Kit	—	—
Safety Breakaway	■	■
Power Slew	—	—
Cushioned Top Link	—	—
Tractor Requirements		
Minimum Tractor Weight	2,500kg	3,000kg
Minimum Tractor Horsepower	45hp	45hp
Specification		
Machine Weight †	563kg	572kg
Left and Right-Hand Build Options	<input type="checkbox"/>	<input type="checkbox"/>

* Including SoftStart ** Excluding axle brackets & latches † Depending on specification, excluding attachment & oil

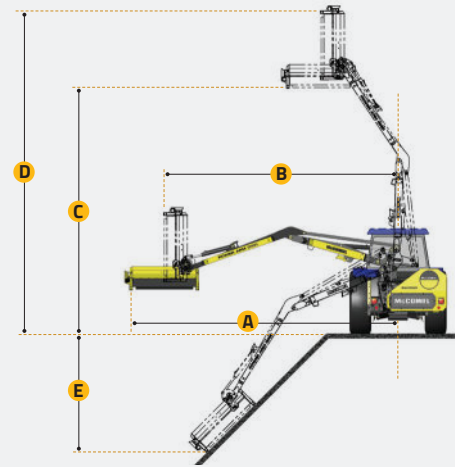

REACH DIMENSIONS

	PA4635-30	PA5035-30
A	4.8m / 15' 9"	5.1m / 16' 9"
B	4.6m / 15' 1"	4.9m / 16' 0"
C	3.2m / 10' 6"	3.4m / 11' 2"
D	5.3m / 17' 5"	5.6m / 18' 4"
E	1.9m / 6' 3"	2.1m / 6' 11"

POWER ARM FLAILHEADS

	PA4635-30	PA5035-30
1.00m Supercut Flailhead - DD	<input type="checkbox"/>	<input type="checkbox"/>
1.20m Supercut Flailhead - DD	<input type="checkbox"/>	<input type="checkbox"/>
1.20m Multicut Flailhead - DD	—	—
1.20m Multicut Flailhead - BD	—	—
1.20m Tuffcut Flailhead - DD	—	—
1.20m Twincut Flailhead - DD	—	—
1.20m Omega Flailhead - DD	—	—
1.20m Omega Flailhead - BD	—	—
1.50m Multicut Flailhead - DD	—	—
1.50m Multicut Flailhead - BD	—	—
1.50m Twincut Flailhead - DD	—	—
1.50m Omega Flailhead - DD	—	—
1.50m Omega Flailhead - BD	—	—
1.60m Multicut Flailhead - DD	—	—
1.60m Multicut Flailhead - BD	—	—
1.60m Tuffcut Flailhead - DD	—	—
1.60m Omega Flailhead - DD	—	—
1.60m Omega Flailhead - BD	—	—
2.00m Multicut Flailhead - DD	—	—
2.00m Multicut Flailhead - BD	—	—
Flailhead options		
Flailhead Skid Kit	<input type="checkbox"/>	<input type="checkbox"/>
Cushioned Grass Mowing Roller	—	—
Hydraulic Roller	—	—
Hydraulic Front Hood	—	—

■ Standard Equipment □ Optional Equipment — Not available

35 SERIES

Specifically designed for ground care, small scale farmers and local government sectors, the 35 series are robust and reliable compact machines.

Available in two reach sizes from 4.8m to 5.1m and powered by 30hp hydraulics the 35 series is suitable for use with smaller tractors of just 45 horsepower and above.

- 2 Reach options from 4.6m to 5.0m
- 2 Advanced control options
- 1 Mounting option
- 1 Armset system
- 2 Flotation systems
- 9 Attachment options

