



POWER ARM
70 SERIES

PA5570 - 5.5m (18' 1") reach
PA6070 - 6.0m (19' 8") reach
PA6570 - 6.5m (21' 4") reach

| 70 SERIES | | | |
|--|--------------------------|--------------------------|--------------------------|
| Advanced Controls | PA5570 | PA6070 | PA6570 |
| Cable Control | — | — | — |
| Motion Mini | — | — | — |
| Motion | <input type="checkbox"/> | <input type="checkbox"/> | <input type="checkbox"/> |
| Evolution | <input type="checkbox"/> | <input type="checkbox"/> | <input type="checkbox"/> |
| Revolution Including Easy Drive System (EDS) | <input type="checkbox"/> | <input type="checkbox"/> | <input type="checkbox"/> |
| Two-way Rotor Engagement - Cable Control (CRC) | — | — | — |
| Two-way Rotor Engagement - Electric Control (ERC)* | ■ | ■ | ■ |
| Mounting | | | |
| Front 3-Point Mounting Including Stabiliser | — | — | — |
| Front DIN Plate Mounting | — | — | — |
| Rear 3-Point Mounting Including Stabiliser | ■ | ■ | ■ |
| Rear 3-Point to 4-Point Hitch Stabiliser Kit | <input type="checkbox"/> | <input type="checkbox"/> | <input type="checkbox"/> |
| Rear 3-Point to 5-Point Axle Mounting Kit** | <input type="checkbox"/> | <input type="checkbox"/> | <input type="checkbox"/> |
| Rear 5-Point Rigid Frame, Axle Mounting Kit** | — | — | — |
| Armsets | | | |
| Straight Armset | <input type="checkbox"/> | <input type="checkbox"/> | — |
| Midcut Armset | — | — | — |
| Telescopic Armset | — | — | — |
| Variable Forward Reach Armset (VFR) | <input type="checkbox"/> | <input type="checkbox"/> | ■ |
| Telescopic-Variable Forward Reach Armset (T-VFR) | — | — | — |
| Parallel Arm Geometry | ■ | ■ | ■ |
| Hydraulics | | | |
| Horsepower | 70hp | 70hp | 70hp |
| System Type | Gear | Gear | Gear |
| Pump Type | Cast | Cast | Cast |
| Total Flow Rate l/min | 160.0 | 160.0 | 160.0 |
| Arm Circuit Flow Rate l/min | 32.0 | 32.0 | 32.0 |
| Attachment Circuit Flow Rate l/min | 128.0 | 128.0 | 128.0 |
| Oil Tank Capacity | 180ltrs | 180ltrs | 180ltrs |
| Oil Cooler | ■ | ■ | ■ |
| Totally Independent Hydraulic System | ■ | ■ | ■ |
| Hydraulic Upgrades | | | |
| Angle Float Kit | ■ | ■ | ■ |
| Lift Float Kit | <input type="checkbox"/> | <input type="checkbox"/> | <input type="checkbox"/> |
| Advanced Float Kit (only on EVOLUTION controls) | <input type="checkbox"/> | <input type="checkbox"/> | <input type="checkbox"/> |
| EDS (only on REVOLUTION controls) | <input type="checkbox"/> | <input type="checkbox"/> | <input type="checkbox"/> |
| PowerBoost (75 l/min Arm Circuit Flow Rate) | — | — | — |
| Additional Hydraulic Services | <input type="checkbox"/> | <input type="checkbox"/> | <input type="checkbox"/> |
| Safety Equipment | | | |
| External Debris Blower | — | — | — |
| Integrated Debris Blower | <input type="checkbox"/> | <input type="checkbox"/> | <input type="checkbox"/> |
| Road Lighting Kit | ■ | ■ | ■ |
| Warning Arrow Kit | <input type="checkbox"/> | <input type="checkbox"/> | <input type="checkbox"/> |
| Window Guards | ■ | ■ | ■ |
| Cab Protection Kit | <input type="checkbox"/> | <input type="checkbox"/> | <input type="checkbox"/> |
| Safety Breakaway | ■ | ■ | ■ |
| Power Slew | ■ | ■ | ■ |
| Cushioned Top Link | ■ | ■ | ■ |
| Tractor Requirements | | | |
| Minimum Tractor Weight | 4,000kg | 4,000kg | 4,500kg |
| Minimum Tractor Horsepower | 100hp | 100hp | 100hp |
| Specification | | | |
| Machine Weight # | 1102kg | 1180kg | 1180kg |
| Left and Right-Hand Build Options | <input type="checkbox"/> | <input type="checkbox"/> | <input type="checkbox"/> |

* Including SoftStart ** Excluding axle brackets & latches # Depending on specification, excluding attachment & oil

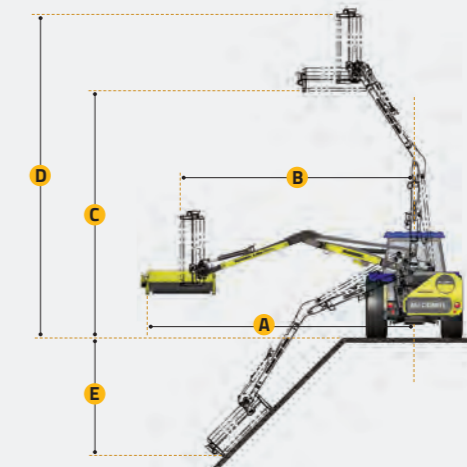

REACH DIMENSIONS

| | PA5570 | PA6070 | PA6570 |
|---|---------------|---------------|---------------|
| A | 5.5m / 18' 1" | 6.0m / 19' 8" | 6.5m / 21' 4" |
| B | 4.9m / 16' 1" | 5.4m / 17' 9" | 5.9m / 19' 4" |
| C | 5.3m / 17' 5" | 5.7m / 18' 8" | 6.0m / 19' 8" |
| D | 6.7m / 22' 0" | 7.1m / 23' 4" | 7.5m / 24' 7" |
| E | 2.4m / 7' 10" | 2.8m / 9' 2" | 3.2m / 10' 8" |

POWER ARM FLAILHEADS

| | PA5570 | PA6070 | PA6570 |
|-------------------------------|--------------------------|--------------------------|--------------------------|
| 1.00m Supercut Flailhead - DD | — | — | — |
| 1.20m Supercut Flailhead - DD | — | — | — |
| 1.20m Multicut Flailhead - DD | <input type="checkbox"/> | <input type="checkbox"/> | <input type="checkbox"/> |
| 1.20m Multicut Flailhead - BD | <input type="checkbox"/> | <input type="checkbox"/> | <input type="checkbox"/> |
| 1.20m Tuffcut Flailhead - DD | — | — | — |
| 1.20m Twincut Flailhead - DD | <input type="checkbox"/> | <input type="checkbox"/> | <input type="checkbox"/> |
| 1.20m Omega Flailhead - DD | <input type="checkbox"/> | <input type="checkbox"/> | <input type="checkbox"/> |
| 1.20m Omega Flailhead - BD | <input type="checkbox"/> | <input type="checkbox"/> | <input type="checkbox"/> |
| 1.50m Multicut Flailhead - DD | <input type="checkbox"/> | <input type="checkbox"/> | <input type="checkbox"/> |
| 1.50m Multicut Flailhead - BD | <input type="checkbox"/> | <input type="checkbox"/> | <input type="checkbox"/> |
| 1.50m Twincut Flailhead - DD | — | — | — |
| 1.50m Omega Flailhead - DD | <input type="checkbox"/> | <input type="checkbox"/> | <input type="checkbox"/> |
| 1.50m Omega Flailhead - BD | <input type="checkbox"/> | <input type="checkbox"/> | <input type="checkbox"/> |
| 1.60m Multicut Flailhead - DD | <input type="checkbox"/> | <input type="checkbox"/> | <input type="checkbox"/> |
| 1.60m Multicut Flailhead - BD | <input type="checkbox"/> | <input type="checkbox"/> | <input type="checkbox"/> |
| 1.60m Tuffcut Flailhead - DD | — | — | — |
| 1.60m Omega Flailhead - DD | <input type="checkbox"/> | <input type="checkbox"/> | <input type="checkbox"/> |
| 1.60m Omega Flailhead - BD | <input type="checkbox"/> | <input type="checkbox"/> | <input type="checkbox"/> |
| 2.00m Multicut Flailhead - DD | — | — | — |
| 2.00m Multicut Flailhead - BD | — | — | — |
| Flailhead options | | | |
| Flailhead Skid Kit | <input type="checkbox"/> | <input type="checkbox"/> | <input type="checkbox"/> |
| Cushioned Grass Mowing Roller | <input type="checkbox"/> | <input type="checkbox"/> | <input type="checkbox"/> |
| Hydraulic Roller | <input type="checkbox"/> | <input type="checkbox"/> | <input type="checkbox"/> |
| Hydraulic Front Hood | — | — | — |

■ Standard Equipment □ Optional Equipment — Not available

Specifically designed for large-scale farmers, contractors, and local government, 70-series machines come with a host of features to enhance performance, efficiency and safety - as well as state-of-the-art controls, flailheads and cutting attachments.

Created from super-strength Domex steel and boasting an advanced feature set with hundreds of different build and customisation options, the series is the perfect choice for professional verge-mowers and hedge-cutters. Its versatility enables operators to customise a machine precisely to their needs.

- 4 Reach options from 5.5m to 7.0m
- 3 Advanced control options
- 3 Mounting options
- 3 Armset options
- 4 Floatation services
- 27 Attachment options





POWER ARM
70 SERIES

PA6570T - 6.5m (21' 4") reach
PA7070T - 7.0m (23' 0") reach

70 SERIES

| Advanced Controls | PA6570T | PA7070T |
|--|--------------------------|--------------------------|
| Cable Control | — | — |
| Motion Mini | — | — |
| Motion | <input type="checkbox"/> | <input type="checkbox"/> |
| Evolution | <input type="checkbox"/> | <input type="checkbox"/> |
| Revolution Including Easy Drive System (EDS) | <input type="checkbox"/> | <input type="checkbox"/> |
| Two-way Rotor Engagement - Cable Control (CRC) | — | — |
| Two-way Rotor Engagement - Electric Control (ERC)* | ■ | ■ |
| Mounting | | |
| Front 3-Point Mounting Including Stabiliser | — | — |
| Front DIN Plate Mounting | — | — |
| Rear 3-Point Mounting Including Stabiliser | ■ | ■ |
| Rear 3-Point to 4-Point Hitch Stabiliser Kit | — | — |
| Rear 3-Point to 5-Point Axle Mounting Kit** | <input type="checkbox"/> | <input type="checkbox"/> |
| Rear 5-Point Rigid Frame, Axle Mounting Kit** | — | — |
| Armsets | | |
| Straight Armset | — | — |
| Midcut Armset | — | — |
| Telescopic Armset | ■ | ■ |
| Variable Forward Reach Armset (VFR) | — | — |
| Telescopic-Variable Forward Reach Armset (T-VFR) | — | — |
| Parallel Arm Geometry | ■ | ■ |
| Hydraulics | | |
| Horsepower | 70hp | 70hp |
| System Type | Gear | Gear |
| Pump Type | Cast | Cast |
| Total Flow Rate l/min | 160.0 | 160.0 |
| Arm Circuit Flow Rate l/min | 32.0 | 32.0 |
| Attachment Circuit Flow Rate l/min | 128.0 | 128.0 |
| Oil Tank Capacity | 180ltrs | 180ltrs |
| Oil Cooler | ■ | ■ |
| Totally Independent Hydraulic System | ■ | ■ |
| Hydraulic Upgrades | | |
| Angle Float Kit | ■ | ■ |
| Lift Float Kit | <input type="checkbox"/> | <input type="checkbox"/> |
| Advanced Float Kit (only on EVOLUTION controls) | <input type="checkbox"/> | <input type="checkbox"/> |
| EDS (only on REVOLUTION controls) | <input type="checkbox"/> | <input type="checkbox"/> |
| PowerBoost (75 l/min Arm Circuit Flow Rate) | — | — |
| Additional Hydraulic Services | <input type="checkbox"/> | <input type="checkbox"/> |
| Safety Equipment | | |
| External Debris Blower | — | — |
| Integrated Debris Blower | <input type="checkbox"/> | <input type="checkbox"/> |
| Road Lighting Kit | ■ | ■ |
| Warning Arrow Kit | <input type="checkbox"/> | <input type="checkbox"/> |
| Window Guards | ■ | ■ |
| Cab Protection Kit | <input type="checkbox"/> | <input type="checkbox"/> |
| Safety Breakaway | ■ | ■ |
| Power Slew | ■ | ■ |
| Cushioned Top Link | ■ | ■ |
| Tractor Requirements | | |
| Minimum Tractor Weight | 4,500kg | 5,000kg |
| Minimum Tractor Horsepower | 100hp | 100hp |
| Specification | | |
| Machine Weight # | 1214kg | 1272kg |
| Left and Right-Hand Build Options | <input type="checkbox"/> | <input type="checkbox"/> |

* Including SoftStart ** Excluding axle brackets & latches # Depending on specification, excluding attachment & oil

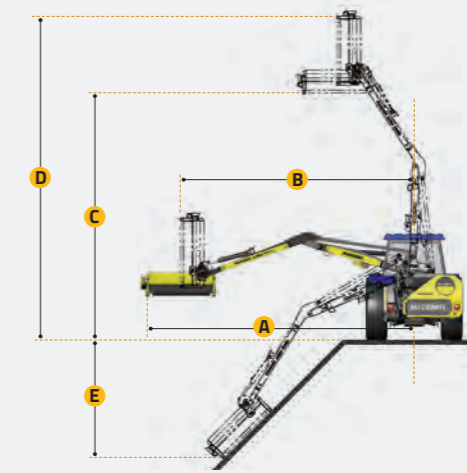

REACH DIMENSIONS

| | PA6570T | PA7070T |
|----------|---------------|---------------|
| A | 6.5m / 21' 4" | 7.0m / 23' 0" |
| B | 5.9m / 19' 4" | 6.4m / 21' 0" |
| C | 5.7m / 18' 8" | 6.1m / 18' 8" |
| D | 7.1m / 23' 4" | 7.1m / 23' 4" |
| E | 3.2m / 10' 8" | 3.5m / 11' 6" |

POWER ARM FLAILHEADS

| | PA6570T | PA7070T |
|-------------------------------|--------------------------|--------------------------|
| 1.00m Supercut Flailhead - DD | — | — |
| 1.20m Supercut Flailhead - DD | — | — |
| 1.20m Multicut Flailhead - DD | <input type="checkbox"/> | <input type="checkbox"/> |
| 1.20m Multicut Flailhead - BD | <input type="checkbox"/> | <input type="checkbox"/> |
| 1.20m Tuffcut Flailhead - DD | — | — |
| 1.20m Twincut Flailhead - DD | — | — |
| 1.20m Omega Flailhead - DD | <input type="checkbox"/> | <input type="checkbox"/> |
| 1.20m Omega Flailhead - BD | <input type="checkbox"/> | <input type="checkbox"/> |
| 1.50m Multicut Flailhead - DD | <input type="checkbox"/> | <input type="checkbox"/> |
| 1.50m Multicut Flailhead - BD | <input type="checkbox"/> | <input type="checkbox"/> |
| 1.50m Twincut Flailhead - DD | — | — |
| 1.50m Omega Flailhead - DD | <input type="checkbox"/> | <input type="checkbox"/> |
| 1.50m Omega Flailhead - BD | <input type="checkbox"/> | <input type="checkbox"/> |
| 1.60m Multicut Flailhead - DD | — | — |
| 1.60m Multicut Flailhead - BD | — | — |
| 1.60m Tuffcut Flailhead - DD | — | — |
| 1.60m Omega Flailhead - DD | — | — |
| 1.60m Omega Flailhead - BD | — | — |
| 2.00m Multicut Flailhead - DD | — | — |
| 2.00m Multicut Flailhead - BD | — | — |
| Flailhead options | | |
| Flailhead Skid Kit | <input type="checkbox"/> | <input type="checkbox"/> |
| Cushioned Grass Mowing Roller | <input type="checkbox"/> | <input type="checkbox"/> |
| Hydraulic Roller | <input type="checkbox"/> | <input type="checkbox"/> |
| Hydraulic Front Hood | — | — |

■ Standard Equipment □ Optional Equipment — Not available

Specifically designed for large-scale farmers, contractors, and local government, 70-series machines come with a host of features to enhance performance, efficiency and safety - as well as state-of-the-art controls, flailheads and cutting attachments.

Created from super-strength Domex steel and boasting an advanced feature set with hundreds of different build and customisation options, the series is the perfect choice for professional verge-mowers and hedge-cutters. Its versatility enables operators to customise a machine precisely to their needs.

- 4 Reach options from 5.5m to 7.0m
- 3 Advanced control options
- 3 Mounting options
- 3 Armset options
- 4 Floatation services
- 27 Attachment options

